



LUBE EQUIPMENT

Lubricant Equipment Catalog

TERMS USED IN THIS CATALOG...

FPT = Female Pipe Thread

NPTF = National Pipe Thread Female (same as FPT)

MPT = Male Pipe Thread

½-27 = 27 Threads Per Inch (Physically the size of ¼" Pipe Thread but very fine threaded)

PSI = Pounds Per Square Inch

Non Metered Oil Control Valve is a trigger operated Oil Dispense Valve without a Meter

Non Preset Metered Oil Control Valve is a Mechanical 16 Quart Meter that reads up to 16 Quarts on the face of the meter. Used primarily with Gasoline Engines where only 3-6 quarts are dispensed at a time

Non Preset Digital Oil Control Valve is an Electronic, Battery Operated, Oil dispense control gun that reads up to 99.9 Pints, Quarts or Gallons depending on how operator wants to dispense oils. Factory Preset to Quarts.

Preset Meter Oil Control Valve is a Mechanical Resettable Oil Dispense Gun that allows operator to preset the amount in quarts up to 60 quarts, he will then insert the nozzle into the oil fill hole, pull the meter trigger which locks open and then the meter counts down to zero, when the meter reaches zero the trigger will automatically unlock and close the dispense valve stopping the flow of oil. Primarily used in Diesel Engine shops where they pump several quarts at a time. 44 Quarts can take up to 5 minutes with most air operated oil pumps.

Preset Digital Oil Control Valve is an electronic, battery operated version of above. Dispenses up to 999.9 Pints, Quarts, or Gallons (some also do Liters) depending on operator settings, factory set to read in quarts. All other workings are exactly like the Mechanical Preset explained above.

Air Pump Ratios i.e. 1:1, 3:1, 5:1, 10:1, 50:1, 75:1 These ratios are very important when determining Volume and Distance the pump is designed to dispense. Normally and in most cases the lower the ratio, 1:1 or 3:1 the higher the volume but the shorter the distance the pump can dispense. The higher the ratio 50:1 or 75:1 dispenses much less volume but will push the product a greater distance. Explaining ratio's with simple math, if you have 100 PSI air pressure with a 1:1 pump you have 100 PSI fluid pressure. Same 100 PSI air pressure with a 5:1 Pump will give you 500 PSI Fluid Pressure. Same 100 PSI air pressure with a 75:1 pump will give you 7,500 PSI fluid pressure. It is important to know what the customer wants to know if you need a lower ratio pump for higher volume or a higher ratio pump for greater distance or multiple dispense points.

SOLUTIONS TO COMMON PROBLEMS...

Grease Pump will not get all the grease out of the drum: With the new grease drum liners it is more difficult to get all the grease out of the drums. When the drum is new have your customer take the excess plastic lining and pull tight to the outside of the drum, than Duct Tape it to the outside of the drum. This will keep the plastic lining from going down as the grease is pumped out and holding up the follower plate. If this solution still doesn't cure the problem. Have your customer add 20-30 lbs of **clean** new chain on top of the follower plate as even as possible- the extra weight of the chain will help force the grease to the bottom of the drum where the pump can pick up the grease. If their follower plate is metal and not all rubber, they can get creative and tack weld the chain to the follower plate.

Hand Operated Grease Guns wont Prime with your grease: This can be an issue with the better quality tackier greases of today. When customer inserts a new tube of grease into the hand grease gun have them do everything as normal- release the T handle to put pressure on the grease, then before pumping grease have them loosen the barrel ¼ turn, then lightly tap the barrel against a work bench or solid surface- this will get trapped air to release through the lose threads allowing the grease to reach the head of the gun. Don't forget to re-tighten the barrel before using.

GREASE GUNS

Pistol-Matic Gun



- 3.5" straight pipe
- 2-way loading
- 5000 psi maximum pressure
- Head cap port for adding air bleeder or bulk loader fitting
- Coupler

Code 10172651



Lever Operated Grease Gun



- Rigid Outlet Pipe
- 2-way loading
- 6000 psi maximum pressure
- Coupler
- 1 oz./40 Strokes

Code 12038342



Lever Operated Hand Grease Gun



- Rigid extension
- 3-way loading
- Air vent
- Loader fitting

Code 10182334



Lever Operated Hand Grease Gun



- 18" Flex extension
- 3-way loading
- Air vent
- Loader fitting

Code 10183962



Pistol Grip Hand Grease Gun



- Rigid extension
- 3-way loading
- Air vent
- Loader fitting

Code 10182966



Pistol Grip Hand Grease Gun



- 18" Flex extension
- 3-way loading
- Air vent
- Loader fitting

Code 10183125



Air Operated Manual Feed

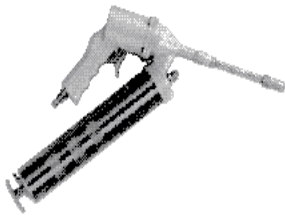

- Rigid extension
- 3-way loading
- Air vent
- Loader fitting
- Coupler

Code 10062248



Air Operated Continuous Flow



- Rigid extension
- 3-way loading
- Air vent
- Loader fitting
- Coupler

Code 12038341



Pistol Grip Hand Grease Gun *Comes in 2 Threadless Barrel Options



Code 12038333
New Lock-N-Load Threadless Quick Connect Barrel

- 12" Flex Extension
- 3-way loading
- Air vent
- Loader fitting

Code 12029917

New Lock-N-Load Threadless Barrel Dual Piston Design. Volume Mode for Normal Greasing, 10,000 PSI Boost Mode



Heavy Duty Lever Grease Gun *Available in both 16oz & 24oz Bulk Fill Capacity

- Rigid extension
- 3-way loading
- Air vent
- Loader fitting
- 10,000 PSI
- High Volume 1 oz./16 Stroke
- High Pressure 1 oz./25 Strokes

Code 10183718

- 16 oz. Bulk Fill Capacity

Code 12038425

- 24 oz. Bulk Fill Capacity



GREASE GUNS ...

UltraView Clear Color Coded Lever Grease Guns



To Stop Cross-Contamination the answer is CLEAR

Benefits of UltraView Clear Grease Guns:

- Identify which type of grease is in the gun
- Equipment can be color coded to match grease gun (see page 36 for color caps)
- Prevent using incorrect grease in equipment
- With Bulk Fill Easily determine amount of grease remaining



Lever Operated Clear Grease Guns Include:

- 3 Way Loading via 14 oz. Cartridge, Suction, or Bulk Fill
- 5.5" curved steel extension
- 12" flexible hose with coupler
- Bulk Loader fitting and air bleeder valve

***Lever Operated
Guns Develop 8,000
PSI and Deliver 1.5 oz.
per 40 strokes.**

Code 12038577 Lever with Black Ends
Code 12036573 Lever with Blue Ends
Code 12038493 Lever with Gold Ends
Code 12038578 Lever with Green Ends
Code 12038579 Lever with Purple Ends
Code 12033737 Lever with Red Ends
Code 12038580 Lever with Silver Ends

UltraView Clear Color Coded Pistol Grip Grease Guns



Pistol Grip Operated Clear Grease Guns Include:















- 3 Way Loading via 14 oz. Cartridge Suction or Bulk Fill
- 5" straight steel extension
- 12" flexible hose with coupler
- Bulk Loader fitting and air bleeder valve



*** Pistol Grip Operated
Guns Develop 5,000
PSI and Deliver 1 oz.
per 40 strokes**

Code 12038581 Pistol with Black Ends
Code 12031612 Pistol with Blue Ends
Code 12038492 Pistol with Gold Ends
Code 12031613 Pistol with Green Ends
Code 12031614 Pistol with Purple Ends
Code 12031611 Pistol with Red Ends
Code 12038582 Pistol with Silver Ends

GREASE GUN ACCESSORIES

	Code: 12029604 Tapered nose heavy duty grease coupler		Code: 12022530 Narrow grease coupler for tight areas
	Code: 12038334 Tight Tolerance 90 degree grease coupler		Code: 10047120 Heavy duty grease coupler
	Hand Operated Grease Gun Whip Hoses 12": 10064308 18": 10064309 36": 12038335		Code: 12038336 Cartridge grease gun holder (Mount to wall, workbench, or safety cabinet storage)
	Code: 12038323 Narrow needle nose adapter with locking sleeve		Code: 12038346 6" Curved rigid outlet with coupler
	Code: 10182996 360 Degree swivel coupler locks into 8 positions		Code: 12038325 90 Degree extension coupler with locking sleeve
	Code: 12038337 All in one tool for 1/8" npt fittings		Code: 10182855 Standard button head coupler pull-on
	Code: 10192459 Heavy Duty zerk-mate to unclog fittings		Code: 10181450 Giant button head coupler pull-on

BATTERY POWERED GREASE GUNS

12 & 14.4 VOLT KITS:



- Lightweight construction, ergonomic design and optional carrying strap reduce physical strain
- Patented automatic universal follower eliminates need to flip the follower when changing load method
- Chrome plated barrel for unmatched durability
- Powerful 1.9 Ampere-hour battery
- 12V delivers up to 13 cartridges, 14.4V delivers up to 17 cartridges of grease at free flow (fully charged)

Code: 10182845
12 Volt Kit (1 Battery)

Code: 12038308
12 Volt Kit (2 Batteries)

Code: 10182730
14.4 Volt Kit (2 Batteries)

ACCESSORIES FOR 12V OR 14.4V GREASE GUNS	12038301 12 VOLT MOBILE CHARGER FOR 12V AND 14.4V BATT.
12038299 14.4 VOLT RECHARGABLE BATTERY	12038424 12 VOLT RECHARGABLE BATTERY
12038300 110 VOLT CHARGER FOR 12V AND 14.4 VOLT BATT.	

18 VOLT LITHIUM ION KITS:

- Up to 27 grease cartridges per battery charge
- 8,000 psi (552 bar)
- 6.0 oz. (170g)/min
- Easy to prime at low temperature
- Durable ultra-flexible Kevlar reinforced hose with flashlight

Code: 12031591
18 Volt Kit (1 Battery)

Code: 12038291
18 Volt Kit (2 Batteries)

ACCESSORIES FOR 18V GREASE GUNS	12038304 12 VOLT MOBILE CHARGER FOR 18 VOLT BATT.
12038302 18 VOLT LITHIUM ION RECHARGABLE BATTERY	12038303 110 VOLT CHARGER FOR 18 VOLT BATT.

*ACCESSORIES FOR 12V, 14.4V OR 18V GREASE GUNS	12022530 REPLACEMENT GREASE COUPLER
12038298 CARRY STRAP FOR BATTERY OPERATED GREASE GUNS	12038305 FLASHLIGHT, ATTACHES TO WHIP HOSE
12019583 36" REPLACEMENT WHIP HOSE	

MISC. GREASE EQUIPMENT



Screw Type Grease Gun

- 8 ounce capacity
- Gun outlet – 1/8" NPTF
- Outlet Extension Required- not included
- *Turning the screw handle dispenses a controlled amount of grease

Code 12025279



Mini-Lube Foot Pump

Code 10029894

- Lightweight, Highly Portable System
- Two Speed Grease Gun Delivers Up To 10,000psi
- 5' Delivery Hose
- 360° swivel prevents hose from kinking
- Rubber edged follower provides wipe down of container walls
- Fully sealed system keeps grease clean
- Model comes complete with refillable 1 gallon container

*To operate the Mini-Lube press the foot plunger. This will prime the pump and provide you with 30 shots of grease through the grease gun. The rubber edged follower ensures you use all the grease in the container.

GREASE GUN FILLERS



Fil-E-Greze Gun Filler (*for loading grease hand guns equipped with loader fitting)

Size	Includes	Code
25-50 lb Pails	Pail cover, metal follower plate, and 1 loader nipple	10029851
120 lb Drum	Pail cover, metal follower plate, and 1 loader nipple	12019434

Optional Accessory

Filler Nipple

Code: 12038339



HEAVY DUTY GREASE GUN FILLERS

Grease Loader Pumps Include Cover, Follower Plate and Loader Coupler

Volume Delivery Pumps for up to NLGI #2 Grease
Delivers 1 LB of grease in 6 Strokes at 500 PSI

Code: 10181454

35 LB Standard or Tapered Pail

Code: 10183974

120 LB Keg

Code: 10182259

Filler Nipple fits Alemite Loader Pumps



HAND OPERATED GREASE GUNS



Code: 12038316

35 LB Grease Bucket Pump with Carry Handle, 5' Hose, Flexible Follower plate (10182482) for use with standard or tapered pails



Code: 10183140

Heavy duty hand operated high pressure (5,000 PSI) grease pump unit. Fits 35 lb. pail. Complete with pump, cover, 5' hose, pipe with coupler, carry handle and follower plate

BEARING PACKERS



Code: 10182490



Bearing Packer 3/4" to 6" Diameter Bearings



Code: 12038311



Bearing Packer 3/4" to 6" Diameter Bearings



Code: 12038313



35 LB Pail Bearing Packer includes Follower Plate 19/32" to 8" Diameter Bearings



Code: 12038312



120 LB Keg Bearing Packer includes Follower Plate 19/32" to 8" Diameter Bearings

SINGLE POINT GREASE LUBRICATORS



Size	Code
1 ounce	10029934
2 ounce	10029948
6 ounce	10029227

Everluber Spring Powered

- Refillable
- Mounts in any direction
- 3 different springs included for different dispensing rates.
- Operating range from -10°F to 250°F

These units provide grease to single bearings at a constant rate. Capable of use in any direction.

Programmable Battery Powered EZ Luber



Code 10070858

- Specially designed, refillable, 5 ounce grease cup.
- Dispensing time from minutes to days..
- Unit can be mounted up to 15' away from lube point for difficult to reach applications.
- Uses AA batteries.

*Accessories for Alemite EZ Luber

- Code 10182607** Replacement Battery
- Code 10183844** Refill Nipple
- Code 10182729** Refill Positioner
- Code 10182757** 1/2" FPT x 1/8" MPT Adapter
- Code 10182364** Refill Cup, 5 ounce

Code: 10182154

- Adjustable Knob controls lubricant flow
- 1.75 oz. Refillable, 1/4" MPT
- Temp Range -40 F to 150 F
- Includes 3 variable pressure springs



STANDARD GREASE DISPENSE PUMPS



35 LB GREASE PUMPS

10182454 35 LB 50:1 PUMP WITH COVER, FOLLOWER PLATE, GREASE GUN, Z-SWIVEL, 12 FT HOSE (GRACO)

10183927 35 LB 50:1 GREASE PUMP INCLUDES COVER, FOLLOWER PLATE, 10' DISPENSE HOSE, GREASE GUN, AND Z-SWIVEL (SAMSON)

10183815 35-50 LB 50:1 GREASE PUMP WITH COVER, FOLLOWER PLATE, 7' DISPENSE HOSE, GREASE GUN AND Z-SWIVEL (ALEMITE)

120 LB GREASE PUMPS

10182774 120 LB 50:1 PUMP WITH COVER, FOLLOWER PLATE, GREASE GUN, Z SWIVEL, 12 FT DISPENSE HOSE (GRACO)

10182933 120 LB 50:1 GREASE PUMP INCLUDES COVER, FOLLOWER PLATE, 15' DISPENSE HOSE, GREASE GUN, Z-SWIVEL, AIR REGULATOR AND MOISTURE SEPARATOR, 18" WHIP HOSE (SAMSON)

10183865 120 LB 50:1 GREASE PUMP WITH COVER, FOLLOWER PLATE, 7' DISPENSE HOSE, GREASE GUN AND Z-SWIVEL (ALEMITE)

400 LB GREASE PUMPS

10183010 400 LB 50:1 PUMP WITH COVER, FOLLOWER PLATE, 5 FT CONNECTION HOSES AND FITTINGS (GRACO)

10185095 400 LB 50:1 GREASE PUMP INCLUDES COVER, FOLLOWER PLATE, 20' DISPENSE HOSE, GREASE GUN, Z-SWIVEL, AIR REGULATOR AND MOISTURE SEPARATOR (SAMSON)

10183793 400 LB 50:1 GREASE PUMP WITH COVER, FOLLOWER PLATE, 20' DISPENSE HOSE, GREASE GUN AND Z-SWIVEL (ALEMITE)

TOTE GREASE DISPENSE PUMPS

10181460 ALEMITE 50:1 GREASE DISPENSE PUMP **10183833** ALEMITE 75:1 GREASE DISPENSE PUMP

TOTE GREASE TRANSFER PUMPS:

10184030 ALEMITE 10:1 GREASE TOTE TRANSFER PUMP, INCLUDES AIR REGULATOR WITH GAUGE, 3/4" X 10' HOSE, AND SHUT OFF VALVE DELIVERS APPROX 73 LBS PER MINUTE

**ALL GREASE TOTE PUMPS INCLUDE 3" CAMLOCK FITTINGS TO ATTACH TO TOTE TANKS*

ADDITIONAL GRACO GREASE DISPENSE PUMPS AND ACCESSORY OPTIONS...



ADDITIONAL PUMPS:

12030695 120 LB 50:1 PUMP WITH COVER, FOLLOWER PLATE, 5 FT CONNECTION HOSES AND FITTINGS

ACCESSORIES:

10183860 DIGITAL GREASE CONTROL VALVE
10183064 GREASE DISPENSE VALVE, 1/4" FPT
10183801 GREASE DISPENSE VALVE, 3/8" FPT
10183065 Z-SWIVEL, 1/4" FPT X 1/4" MPT
10190979 Z-SWIVEL, 3/8" FPT X 3/8" MPT
12029604 HYDRAULIC COUPLER, 1/8" FPT
10046438 AIR REGULATOR WITH GAUGE, 3/8"
10182970 WHIP HOSE, HIGH PRESSURE, 30"
12038332 GREASE REEL WITH 3/8" ID X 50FT HOSE
10183855 35 LB BAND DOLLY

10064452 120 LB BAND DOLLY
12038349 120 LB BASE DOLLY
10182995 400 LB DRUM DOLLY
12032962 35 LB OR 120 LB 4 WHEEL DRUM CART
10185370 1/4" X 10' GREASE DISPENSE HOSE
12023211 1/4" X 20' GREASE DISPENSE HOSE
10182699 1/4" X 30' GREASE DISPENSE HOSE
10046725 3/8" X 50' GREASE DISPENSE HOSE
12038332 3/8 X 50' RETRACTABLE GREASE REEL

ADDITIONAL SAMSON GREASE DISPENSE PUMPS AND ACCESSORY OPTIONS...



ADDITIONAL PUMPS:

10181507 120 LB 50:1 GREASE PUMP INCLUDES COVER, FOLLOWER PLATE, 15' DISPENSE HOSE, GREASE GUN, Z-SWIVEL, AIR REGULATOR AND MOISTURE SEPARATOR, 18" WHIP HOSE, AND BAND DOLLY

12038351 120 LB 50:1 GREASE PUMP INCLUDES COVER, FOLLOWER PLATE, 15' DISPENSE HOSE, GREASE GUN, Z-SWIVEL, AIR REGULATOR AND MOISTURE SEPARATOR, 18" WHIP HOSE, AND TRUCK DOLLY

ACCESSORIES:

10185233 BARE 35 LB GREASE PUMP
10185288 BARE 120 LB GREASE PUMP
12038584 BARE 400 LB GREASE PUMP
10185245 35 LB FOLLOWER PLATE
10182476 SPECIAL NARROW 35LB FOLL. PLATE
10181850 120 LB FOLLOWER PLATE
10185232 400 LB FOLLOWER PLATE
10181117 GREASE CONTROL VALVE

10182744 Z-SWIVEL 1/4" MPT X 1/4" FPT
10185237 Z-SWIVEL 1/2"-27 MALE X 1/4" MPT (FOR OLDER PKG)
10183980 MINI AIR REGUALTOR W/MOISTURE SEPARATOR
10182337 HOLD DOWN KIT 120LB DRUM FOR TRUCK MOUNT
12023211 1/4" X 20' GREASE DISPENSE HOSE
10182699 1/4" X 30' GREASE DISPENSE HOSE
10046725 3/8" X 50' GREASE DISPENSE HOSE

ADDITIONAL ALEMITE GREASE DISPENSE PUMPS AND ACCESSORY OPTIONS...



ADDITIONAL PUMPS:

12019243 50LB 50:1 GREASE PUMP WITH 50 LB PAIL, CART, COVER, FOLLOWER PLATE, 7' DISPENSE HOSE, GREASE GUN AND Z-SWIVEL

12038320 120 LB 50:1 GREASE PUMP WITH COVER, FOLLOWER PLATE, 20' DISPENSE HOSE, AIR REGULATOR WITH GUAGE, MOISTURE SEPARATOR, GREASE GUN AND Z-SWIVEL

12038319 120 LB 50:1 GREASE PUMP WITH COVER, FOLLOWER PLATE, 7' DISPENSE HOSE, GREASE GUN, Z-SWIVEL, TRUCK TIE DOWN KIT, AND 3/8 X 50' GREASE REEL

10184264 120 LB 50:1 GREASE PUMP WITH COVER, FOLLOWER PLATE, 7' DISPENSE HOSE, GREASE GUN, Z-SWIVEL, AND 3/8 X 50' GREASE REEL

12025942 120 LB 75:1 GREASE PUMP WITH COVER AND FOLLOWER PLATE

12028939 400 LB 50:1 GREASE PUMP WITH COVER AND FOLLOWER PLATE

12038322 400 LB 50:1 GREASE PUMP WITH COVER, FOLLOWER PLATE, 10' CONNECTION HOSE, GREASE GUN, Z-SWIVEL, AND 3/8 X 50' GREASE REEL

BARE PUMPS:

12038317 35 LB 50:1 PUMP ONLY

12038318 120 LB 50:1 PUMP ONLY

12025481 120 LB 75:1 PUMP ONLY

12010995 400 LB 40:1 PUMP ONLY

12038321 400 LB 50:1 PUMP ONLY

12031701 400 LB 75:1 PUMP ONLY

ACCESSORIES:

12038585 35 LB PAIL COVER W/CARRY HANDLE

12038426 120 LB DRUM COVER

12038296 400 LB DRUM COVER

10182482 35 LB FOLLOWER PLATE

10183017 120 LB FOLL. PLATE FOR RAM PUMPS

10185351 400 LB FOLL. PLATE FOR RAM PUMPS

12038297 400 LB FOLL. PLATE FOR 7700 SERIES PUMPS

10185322 GREASE GUN, 1/4" FPT

10185372 Z-SWIVEL 1/4" MPT

10182996 8 POSITION SWIVEL COUPLER

10047120 HEAVY DUTY GREASE COUPLER

12022530 NARROW GREASE COUPLER

12038325 90 DEGREE EXTENSION COUPLER WITH SLEEVE

10184377 3/8 X 50' GREASE HOSE REEL, SPRING RETRACTABLE

12038314 BARE GREASE REEL, HOLDS UP TO 50' OF 3/8" HOSE

10182949 3/8 X 80' GREASE HOSE REEL, SPRING RETRACTABLE

12038295 TIE DOWN ROD KIT FITS 120 LB PUMPS

10183980 1/4" AIR REGULATOR AND MOISTURE SEPARATOR

12038327 HOSE 1/4" X 7' W/ 1/2-27 FEMALE BOTH ENDS, 5000 PSI

10037161 HOSE 1/4" X 20' W/ 1/2-27 FEMALE BOTH ENDS, 5000 PSI

12038837 HOSE 1/4" X 30' W/ 1/2-27 FEMALE BOTH ENDS, 5000 PSI

10184377 3/8 X 50' RETRACTABLE GREASE REEL

12038314 BARE RETRACTABLE GREASE REEL, HOLDS 1/4 OR 3/8 BY 50FT

10182949 3/8 X 80' RETRACTABLE GREASE REEL

ADDITIONAL GREASE DISPENSE PUMPS AND ACCESSORY OPTIONS...



MISCELLANEOUS ACCESSORIES:

12038428 STANDARD BUTTON HEAD COUPLER WITH WHIP HOSE, CAN BE ADDED TO ANY GREASE DISPENSE HAND OR AIR OPERATED GUN

10183860 DIGITAL GREASE DISPENSE GUN, READS IN OUNCES, FLOW RATE UP TO 36 OUNCES PER MINUTE, CAN BE ADDED TO ANY AIR OPERATED GREASE PUMP WITH MAXIMUM PRESSURE OF 5000 PSI, 1/4" FPT Inlet

10183889 STRAIGHT SWIVEL 1/4" MPT X 1/2-27 MALE

10184228 Z-SWIVEL 1/4" MPT X 1/2-27 MALE

12038350 ADAPTER 1/4" FPT X 1/2-27 FEMALE

12038306 ADAPTER 1/2-27 MALE X 1/2-27 MALE

12038327 HOSE 1/4" X 7' WITH 1/2-27 FEMALE BOTH ENDS, 5000 PSI

10037161 HOSE 1/4" X 20' WITH 1/2-27 FEMALE BOTH ENDS, 5000 PSI

12038837 HOSE 1/4" X 30' WITH 1/2-27 FEMALE BOTH ENDS, 5000 PSI

** 1/2-27 Thread is a fine thread fitting, hard to locate in most areas, we can supply many variation's of straight or Z-Swivel that includes this hard to find thread as well as adapters to convert to National Pipe Thread, also hose assemblies with 1/2-27 Female on both ends being used by Alemite, Lincoln and Balcrank Equipment*

12038324 18" FLEX WHIP HOSE 6000 PSI WORKING PRESSURE, 1/8" MPT

10182970 30" FLEX WHIP HOSE 5000 PSI WORKING PRESSURE, 1/8" MPT

12029604 TAPERED NOSE HEAVY DUTY GREASE COUPLER



GREASE HOSE REELS:

12030313 HANNAY 1 1/4" X 25' RETRACTABLE GREASE REEL—FOR VOLUME TRANSFER

12028303 RAASM 3/8 X 50' RETRACTABLE GREASE REEL

12025221 RAASM BARE RETRACTABLE GREASE REEL, HOLDS 1/4 OR 3/8 BY 50FT

12031189 RAASM 1/2 X 50' RETRACTABLE GREASE REEL

12032194 RAASM 3/8 X 80' RETRACTABLE GREASE REEL

12031158 RAASM 3/8 X 100' RETRACTABLE GREASE REEL

12023172 RAASM BARE RETRACTABLE GREASE REEL HOLDS 3/8 OR 1/2 BY 100'

12023427 RAASM 1" X 30' RETRACTABLE GREASE REEL FOR VOLUME TRANSFER

00/000 GREASE PUMPS



POURABLE GREASE DISPENSE SYSTEMS:

*Designed to pump heavy weight gear oils and light weight pourable greases, use for Track Lube, Cotton Picker Lube, Filling Automatic Lubrication Systems used in Fracking, Trucking, and Off Road Machinery.

Code: 12038583

35 LB Pail Package includes Cover, Air Regulator, 15' Dispense hose, Grease Gun and Z-Swivel

Code: 12028568

120 LB Keg Package includes Cover, Air Regulator, 25' Dispense hose, Grease Gun and Z-Swivel



Code: 12031690

Hand Operated Reservoir Filler Pump for 000 to NLGI #2 Greases. Fills Automatic Lubricators using Hydraulic Quick Connect Fittings. Male Fitting included with Graco G3 Lubricators.



Code: 12019947



Male Fitting used with 12031690

Code: 12033704



Male Fitting Kit to adapt Lincoln Quicklube Reservoirs to use 12031690 Filler Pump

STANDARD PAIL/KEG/DRUM OIL PUMPS



Code 10010046

Lever-Matic Drum Pump

Can Be Used w/these Products:

- Designed for the transfer of liquid products from a barrel to a smaller container.
- Can be used on containers from 5 to 55 gallons.
- Polypropylene housing.
- Will pump water, gasoline, light oils, solvents, thinners and petroleum products.
- Viton seals.
- Can be used on containers from 5 to 55 gallons.

- Fuel Improvers
- Automatic Transmission Fluid
- All motor oils
- TO-4 oils
- Vacuum pump oils
- Gear oil from ISO 68 to ISO 220
- Hydraulic oil from ISO 22 to ISO 220

*The Following 4 Pumps Can Be Used With these Products:

- ATF
- TO-4 Oil
- Gear oil up to SAE 80W-90
- Hydraulic oil from ISO 22 to ISO 220 including 10W-30.
- All motor oils
- Universal Tractor oil
- Gear oil from ISO 68 to ISO 220



*30-55 GL Drum Pump

Code: 12038347



Fits 30-55 gallon drums. Pump delivers 10ozs. per stroke. Designed for efficient transfer of petroleum-based, non-corrosive liquids.

Includes:

- Pump
- Standard bung bushing
- Corrosive-resistant finish
- Curved metal spout w/threads to fit garden hoses

*CT-7 Pump

Code 10033516



Fits 5 GL bucket. Dispenses 1 to 2.5 ounces per stroke.

Includes:

- Pump
- 4' of clear hose
- Curved nozzle
- Buna seals
- Powder coated lid.



*5 GL (35#) Lever Action Bucket Pump

Code: 12038338

Fits 25-50 lb. Buckets. Perfect for transferring transmission fluid or heavier fluids.

Includes:

- Pump
- 18" drum cover
- 4' delivery hose



*55 GL (400#) 1 Qt/Stroke Hand Pump

Code: 10037129



Includes:

- Pump w/Vacuum Breaker
- 2" Bung Adapter
- 1" Inlet & 3/4" Outlet
- 8' Hose & Nozzle
- Telescoping Suction Pipe, reaches 22-40".
- Release 1 Quart per Stroke

STANDARD DRUM AND TOTE OIL PUMPS

Oil Tote Pump Package Includes:

- Graco 3:1 Oil Pump
- Air Regulator
- Moisture Separator
- Suction Tube
- 1/2 x 50' Raasm Oil Hose Reel
- Pump to Reel Oil Connection Hose

Code: 12022757

Digital Metered Oil Control Valve. Reel Support Bracket Optional see code **10181532**

Code: 12023332

Non Metered Oil Control Valve, and Reel Supporting Bracket as pictured on tote tank.

Code: 12019071

Mechanical Preset Metered Oil Control Valve. Reel Support Bracket Optional see code **10181532**. *This Pump can be used for Totes or Drums

Oil Tote Pump Package Includes:

- Graco 3:1 Oil Pump
- Air Regulator
- Moisture Separator
- Suction Tube
- 1/2 x 80' Raasm Oil Hose Reel
- Pump to Reel Oil Connection Hose

Code: 12027460

Non Metered Oil Control Valve. Reel Support Bracket Included

Code: 12027459

Mechanical Preset Metered Oil Control Valve. Reel Support Bracket Included

ADDITIONAL OIL PUMPS



Code: 10184732



5:1 Stub Length 7 GPM Oil Pump
 •Handles Fluids up to SAE 140
 •1 1/2" FPT Material Inlet
 •1/2" FPT Material Outlet
 •1/4" FPT Air Inlet
 •Pick Up Tube and Access order Separate



Code: 10185383



5:1 Stub Length 2.8 GPM Oil Pump
 •Handles Fluids up to SAE 140
 •1 1/2" FPT Material Inlet
 •1/2" FPT Material Outlet
 •3/8" FPT Air Inlet
 •Pick Up Tube and Access order Separate

Code: 12028306

16-55 Gal Drum, Tote, Tank

3:1 Universal Length 7.8 GPM Oil Pump
 Fits any size Drum, Tote or Tank up to 37" In Depth- cut to fit
 Includes: 10' Dispense Hose and **Non Metered** Oil Control Valve
 Requires 2" FPT Opening for Pump Mounting



Code: 12038331

16-55 Gal Drum, Tote, Tank



5:1 Universal Length 6.7 GPM Oil Pump
 Fits any size Drum or Tank up to 37" In Depth- cut to fit
 No other accessories included
 Requires 2" FPT Opening for Pump Mounting

Code: 12030382

16-55 Gal Drum, Tote, Tank

3:1 Universal Length 7.8 GPM Oil Pump
 Fits any size Drum, Tote or Tank up to 37" In Depth- cut to fit
 Includes: 20' Dispense Hose and **Non-Preset Metered** Oil Control Valve
 Requires 2" FPT Opening for Pump Mounting

Code: 10185345

55 Gal Drum

5:1 55 Gallon Length 2.8 GPM Pump with Bung Adapter, 2" FPT Opening for Pump Mounting Required, 10' Dispense Hose, and Shut Off Valve



Graco Oil Transfer Pump

Code 10185331 Drums

Code 10185314 Totes

Typical Fluids Pumped:

- Motor oil, Synthetic Oils, Hydraulic Oil, Gear Oil, ATF

*Package includes 15' supply air hose and 15' liquid discharge hose.



Graco 16 Gallon Oil Dispense Pumps

Code 10182846

Code 10182885

16 Gallon Oil Package Includes:
 16 Gallon Drum Length Pump
 20' Dispense Hose
 16 Gallon Drum Dolly

Non Metered Oil Control Valve

16 QT Metered Oil Control Valve



Double Diaphragm Transfer Pump

For rapid pumping from drums or totes to customer's bulk storage containers.

Typical Fluids Pumped:

- Motor oil, Synthetic Oil, Hydraulic Oil, Gear Oil, Antifreeze, Diesel Fuel, etc.



Code 12033276 1/4" Double Diaphragm Pump Max 5 GPM at 9 SCFM

Code 10184450 3/4" Double Diaphragm Pump Max 16 GPM at 28 SCFM

Code 12032184 1" Double Diaphragm Pump Max 50 GPM at 67 SCFM

Code 10185327 1 1/2" Double Diaphragm Pump Max 90 GPM at 90 SCFM

Code 12029186 2" Double Diaphragm Pump Max 150 GPM at 175 SCFM

Hose Assemblies:

Code 12019626 1" x 30' Suction Hose with 1" Camlock Fittings

Code 12019627 1" x 30' Discharge Hose with 1" Camlock Fittings

Code 10185339 1 1/2" x 10' Suction Hose with 1 1/2" Camlock Fittings

Code 12030470 1 1/2" x 30' Discharge Hose with 1 1/2" Camlock Fittings

ANTIFREEZE TOTE PUMP

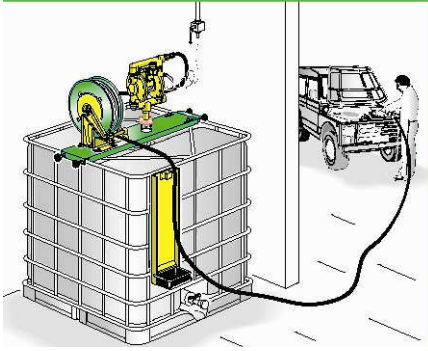

Code: 12023535

Includes:

3/4" Double Diaphragm Pump
Air Regulator
Moisture Separator

1/2 x 50' Water Hose Reel
Non Metered Control Valve
Reel Support Bracket

GRAVITY FEED OIL DRUM & TOTE PUMPS

**To transfer oil from 55 gallon drums or 330 gallon totes into smaller containers.*

55 Gallon Package Code: 10185250

Tote Package Code: 10185266

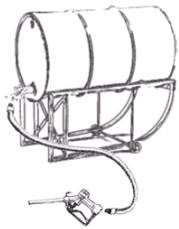

Cradle not included

Cradle Code 10029799



Includes	Code
Connectors	10185364
12' Hose	10185321
Camlock Fitting	10185384

Optional Accessories	Code
Gravity Flow Meter	10185338

MISCELLANEOUS PUMPS



Code: 12038586



Model 262

- Unique 2:1 long stroke 55 Gallon- one pump for all fluids, including gear lube.
- Non-drip, spring loaded valve.
- Shelf holds container - catches spills - drains back through filtered bushing into drum.



Code: 12037906



- Mobile Lube Cart for 55 Gallon Drum, Oils and Lubricants
- 3:1 55 Gallon Length 5.3 GPM Pump
- Heavy Duty Dolly with Reel Mount Support
- 1/2 x 35' Oil Reel- Spring Retractable
- Digital Non Preset Oil Control Meter, 1/2" FPT Swivel Inlet

MISCELLANEOUS PUMPS CONT'D...

Oils, Antifreeze, Diesel Fuel,
Chemicals, Soaps Transfer

Code 12025606

Drum or Tote ¾" Double Diaphragm
Pump Package includes: Air Regulator,
¾ x 20' Hose, and On-Off Nozzle for
Transfer rates up to 16 GPM



Diesel Fuel Treatment Package Can also be
used for Diesel Fuel and Kerosene

Code 12026192

Drum or Tote ¾" Double Diaphragm
Pump Package includes: Air Regulator,
¾ x 25' Hose, Automatic Shut Off
Nozzle, and In-Line Digital Flow Meter
for Transfer rates up to 16 GPM

ELECTRIC OPERATED PUMP-OFF SYSTEMS

For pumping from drums or totes to customer's bulk storage containers where compressed air not available.

Oil Transfer Pump - 110 Volt Electric

Code 10185107



- Electric motor driven gear type pump.
- Self priming, positive displacement design.
- Mounts directly on barrel with adaptor supplied.
- Built in bypass valve and on/off switch.
- AC model has built-in 30" three-prong power cord.
- ½ horsepower motors supply the necessary power to pump viscous fluids.
- Kit comes complete with suction pipe, 8 ft. hose, nozzle, and bung adaptor.
- Can be used to transfer used oil with suction screen.

Typical Fluids Pumped:

- Motor oil.
- Synthetic oil.
- Hydraulic oil.
- Gear oil.
- Automatic transmission fluid.

Transfer rate: 4 GPM to 6 GPM depending on viscosity.

Code 12026523



110 Volt AC Pump with ¾" X 20' Hose Reel and On-Off
Nozzle



For rapid pumping from drums or totes to customer's bulk containers where compressed air not available.

High Speed Transfer Pump-Electric



Typical Fluids Pumped:

- Motor oil.
- Synthetic oil.
- Hydraulic oil.
- Gear oil.
- Automatic transmission fluid.

Code 12030360

- Delivers 30 to 60 gal. per minute
- Dimensions: L = 29.5", W = 16", D = 13.5"
- 12 Volt DC

Code 10185344

- Delivers 30 to 60 gal. per minute
- Dimensions: L = 29.5", W = 16", D = 13.5"
- 110 or 220V



MULTI-PURPOSE HAND PUMPS



Rotary Hand Pump

Code: 10183716

Rotary Barrel Pump. Heavy Duty Cast Iron Body, Telescopic Steel Suction Tube, Adjustable Bung fits 16-55 Gallon Drums. Dispenses Fuel Oils, Kerosene, Diesel Fuel Oils, Oils, and other Light Liquids. Includes 5' Dispense Hose Assembly

FILL-RITE



Fill Rite Piston Hand Pump

Code: 10182952

Includes:

- Pump w/Vacuum Breaker
- 8' Hose & Nozzle
- 2" Bung Adapter
- Telescoping Suction Pipe, reaches 22-40"
- 1" Inlet & 3/4" Outlet
- Releases 1/5 gal. per Stroke

Can be used w/these products:

- Fuel Improvers
- Diesel Fuel #1 or #2.
- Solvents
- Gasoline
- Light oil
- Kerosene

FILL-RITE



Fill Rite Rotary Hand Pump

Code: 10182596

10 Gallons per 100 Revolutions
UL Approved

Cast aluminum Fill-Rite pump provides smooth, continuous transfer of medium viscosity liquids, as well as oil, gasoline and diesel fuel. Improved seal keeps water out. Built-in check valve and strainer. Pump easily mounts to a standard drum with 2in. NPT. Anti-siphoning device, 8' hose with static wire and a 22in. to 40in. telescoping suction pipe. Pad-lockable pump can be set up for reverse flow and is adaptable for drums, kegs or storage tanks. U.S.A.



Lift Action 55 Gallon Stainless Steel Hand Pump

Code: 12024283

Includes:

- Stainless Steel Pump w/Teflon
- 22 Fluid oz per Stroke
- Seals
- Discharge Spout can be Rotated 180
- 2" Adjustable Bung Adapter
- Degrees and can be removed to expose garden hose threads
- 1 1/2" Inlet & 3/4" Outlet

Can be used w/these products:

- Fuel Improvers and Additives
- Corrosive Fluids.
- Solvents
- Aggressive Chemicals
- Light oil, Motor Oil
- Kerosene, and Diesel
- Lacquer Thinner
- Cleaning Solutions



Lift Action 5 Gallon Hand Pump

Code: 10182188

*Pump attaches to Reike Pull Up Spout Threads

Plastic Bucket Pump with Zinc-Plated Steel Tube for Transferring Non-Corrosive fluids Engine Oil, Gear Oil, Transmission Fluid, Automotive Additives, Machine Oils, etc. Includes 50" Oil Resistant Flex Hose with Non-Drip Nozzle. Discharge rate 3 oz. Per Stroke. Bucket in picture not included.

OIL CONTROL VALVES



Code 12038430



ATF, Motor Oil, Hydraulic Oil

Non Metered Oil Control Valve, 1/2" FPT inlet Swivel, Flexible Outlet with Manual Non Drip Nozzle, 1500 PSI Max Fluid Pressure, 6.6 GPM



Code 12038427



ATF, Gear Oil, Hydraulic Oil

Non Metered Oil Control Valve, 1/2" FPT inlet Swivel, Rigid/Flex Outlet with Semi-Automatic Non Drip Nozzle, 1500 PSI Max Fluid Pressure, 6.6 GPM



Code 10185240



Motor Oil, Hydraulic Oil

Non Metered Oil Control Valve, 1/2" FPT inlet Swivel, Rigid Outlet with Semi-Automatic Non Drip Nozzle, 1500 PSI Max Fluid Pressure, 6.6 GPM



Code 12028843



Motor Oil, Hydraulic Oil

Non Metered Oil Control Valve, 3/4" FPT inlet Swivel, Rigid Outlet with Locking Trigger Quick Close Non Drip Nozzle, 1500 PSI Max Fluid Pressure, 20 GPM



Code 12038330



Motor Oil, Hydraulic Oil, ATF

16 Quart Non Preset Metered Oil Control Valve, 1/2" FPT inlet Swivel, Flexible Outlet with Manual Non Drip Nozzle, 1000 PSI Max Fluid Pressure, 4 GPM Max



Code 10185360



Motor Oil, Hydraulic Oil, ATF

16 Quart Non Preset Metered Oil Control Valve, 1/2" FPT inlet Swivel, Flexible Outlet with Manual Non Drip Nozzle, 1000 PSI Max Fluid Pressure, 4 GPM Max



Code 12022534



Motor Oil, Hydraulic Oil

60 Quart Preset Metered Oil Control Valve, 1/2" FPT inlet Swivel, Rigid Outlet with Automatic Non Drip Nozzle, 1000 PSI Max Fluid Pressure, 4 GPM Max



Code 10184232



Motor Oil, Hydraulic Oil

60 Quart Preset Metered Oil Control Valve, 1/2" FPT inlet Swivel, Rigid Outlet with Automatic Non Drip Nozzle, 1000 PSI Max Fluid Pressure, 4 GPM Max



Code 10182211



Lubricants up to SAE 140

Digital Non Preset Metered Oil Control Valve, 1/2" FPT inlet Swivel, Flexible Outlet with Manual Non Drip Nozzle, 1500 PSI Max Fluid Pressure, 5.25 GPM Max, uses standard AAA Batteries, Display in Quarts, Totals in Gallons



Code 12032420



Oils and Anti-Freeze

Digital Preset Metered Oil Control Valve, 1/2" FPT inlet Swivel, Rigid Outlet with Automatic Non Drip Nozzle, 1000 PSI Max Fluid Pressure, 5 GPM Max, uses standard 9 Volt Batteries, Display's in Pints, Quarts, Gallons or Liters. Factory set in Qts, Totals in Gallons



Code 12038329

High Flow Digital Non Preset Electronic Meter

- 0.1-14 GPM
- 1500 PSI Maximum
- 3/4" FPT Inlet Swivel
- Rigid Extension with Quick Close Non Drip Tip
- 4 AA Batteries, Included



Code 10175855

Replacement Whip Hose with Manual Non Drip Tip

Code 12024451



Replacement High Flow Nozzle for Mechanical Preset Meters

OIL ACCESSORIES



Code 12038344

1/2" Ball Valve, 600 PSI



Code 10187268

Graco Fireball/Fastball Pump Bung Adapter, 2"



Code 12028062

Scully String Gauge, fits up to 72" Tall Tanks/Drums, Calibrate to fit. 1/2" and 2" Male Threads



Code 12038345

Suction Pipe 37" Cut to Fit



10185275 1/2" x 10', 2000 PSI Oil Hose, 1/2" Male Pipe Thread Both Ends
10182848 1/2" x 20', 2000 PSI Oil Hose, 1/2" Male Pipe Thread Both Ends
10182951 1/2" x 50', 2000 PSI Oil Hose, 1/2" Male Pipe Thread Both Ends
12031172 1/2" x 150', 2000 PSI Oil Hose, 1/2" Male Pipe Thread Both Ends



Code 12028838

CLEANLINE Filter 1800 PSI Max

- 99.9% Efficient at 10 Microns
- Compatible with All Oils and Antifreeze
- Replacement Element Code **12028839**

AIR ACCESSORIES



Code 10183980

1/4" Mini Air Regulator with Gauge and Moisture Separator

Code 12033688

1/2" Regulator w/ Filter



Code 10181614

3/8" x 50' Air Hose with 3/8" Male Pipe Thread x 1/4" Male Pipe Thread



Code 12036256

3/8" Air Line Lubricator with 5 ounce bowl Capacity



Code 10046438

3/8" Air Regulator with Gauge

OIL, AIR AND WATER HOSE REELS



10182950 Alemite 1/2" x 50' Reel, 1500 PSI Max
12038315 Alemite Bare Oil Reel, Holds up to 1/2" x 50' Hose, 1500 PSI Max



12034525 Alemite 3/4" x 50' Oil/Fuel Reel, 1000 PSI Max
10183034 Alemite 1" x 50' Oil/Fuel Reel, 1000 PSI Max
12022533 Graco 1/2" x 50' Reel, 2000 PSI Max



10183914 Alemite 3/8 x 50' Hose Reel, Retractable
12038315 Alemite Bare Hose Reel, Holds 1/4", 3/8", or 1/2" x 50'
10182404 Alemite 3/4 x 30' Low Pressure Hose Reel, Retractable
12028302 Raasm 3/8 x 60' Hose Reel, Retractable
12027407 Raasm 1/2 x 50' Hose Reel, Retractable

Oil Hose Reels

12028301 Raasm 1/2" x 50' Reel, 2000 PSI Max
12026535 Raasm 1/2" x 80' Reel, 2000 PSI Max
12023171 Raasm Bare Oil Reel Holds up to 1/2" x 100' Hose, 2000 PSI Max
12028304 Raasm 3/4" x 50' Reel, 2000 PSI Max
12020898 Raasm 1" x 50' Reel, 2000 PSI Max

Air and Water Hose Reels

12028833 Raasm 3/4 x 50' Hose Reel, Retractable
12038467 Raasm 3/8 x 100' Hose Reel, Retractable
12023173 Raasm 1/2" x 100' Hose Reel, Retractable
12025478 Raasm 1" x 50' Hose Reel, Retractable

FUEL TREATMENT PUMPS

Solar Powered Direct-Inject™ Diesel Fuel Treatment Pump



- Injects the correct amount of fuel treatment every time fuel is delivered.
- Solar powered – requires no electrical or compressed air connection.
- Available in push button or automatic configurations.
- Multiple options for installation.
- Durable & Reliable

Call your manager for more information.
Available on contract only.

Lever-Matic Drum Pump **Code 10010046**

Can be used with Diesel Fuel Improver



- Designed for the transfer of liquid products from a barrel to a smaller container.
- Can be used on containers from 5 to 55 gallons.
- Polypropylene housing with stainless steel shaft.
- Viton seals.
- Can be used on containers from 5 to 55 gallons.

DIESEL EXHAUST FLUID PUMPS



Rotary Hand Pump 30-55 Gallon Drum

Code: 10173740

Includes:

- Buttress Adapter to convert threads to 2" NPT
- 9 FT Dispense Hose
- Stainless Steel Spout
- Adjustable Pick Up Tube
- Adjustable Bung Adapter
- 4 GPM Pump Rate



110 Volt AC 55 Gallon Drum Kit

Code: 12030504

Includes:

- Stainless Steel Bracket to Attach Pump to Drum
- Drum Quick Connector with Pick Up Tube
- 18 FT Delivery Hose
- Manual Nozzle with Nozzle Holder Bath
- 7 GPM Flow Rate



110 Volt AC Tote Metered Kit

Code: 12030509

Includes:

- Stainless Steel Bracket to Attach Pump to Tote Tank
- Stainless Steel DS-DV SV Coupler is Included
- 20 FT Delivery Hose
- Automatic Nozzle with Nozzle Holder Bath
- 7 GPM Flow Rate
- Digital Meter



Code: 12027536

Same as Above except without Meter and with Manual Nozzle



Air Operated DEF Package for Totes

Code: 12030124

Includes:

- Stainless Steel Bracket to Attach Pump to Tote Tank
- Quick Connect Inlet kit is Included
- 20 FT Delivery Hose, 6 FT Suction Hose
- Automatic Nozzle with Nozzle Holder Bath
- Air Regulator with Vent and 50 PSI Valve



Air Operated DEF Package for Drums

Code: 12028061

Includes:

- Stainless Steel Bracket to Attach Pump to Drum
- Quick Connect Inlet kit is Included
- 12 FT Delivery Hose, 2 FT Suction Hose
- Automatic Nozzle with Nozzle Holder Bath
- Air Regulator with Vent and 50 PSI Valve

AUTOMATIC LUBRICATION SYSTEMS

*For more information, please call Terry Stookey at Reliable Hydraulics by filling out and sending him the Lubrication Equipment Questionnaire. [CLICK HERE FOR FORM.](#)

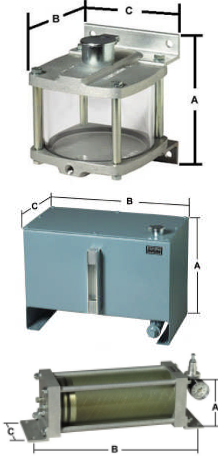

Reservoirs to Fit Your Needs



Divider blocks for lubricant distribution.

Typical fluids pumped:

- Grease, 000, 00, #1, #2.
- Oils from ISO 22 to ISO 680.

These engineered devices are designed for the automatic lubrication of:

- Chains
- Cables
- Bearings
- Guideways, etc.

*For more information, please call Terry Stookey at Reliable Hydraulics by filling out and sending him the Lubrication Equipment Questionnaire. [CLICK HERE FOR FORM.](#)

STORAGE & DISPENSING SYSTEMS...

- Customized rack storage dispensing systems built to customer requirements.
- Central location allows for easy inventory tracking.
- Confines spillage to one location.
- Allows proper dilutions for water-diluted products.



*For more information, please call Terry Stookey at Reliable Hydraulics by filling out and sending him the Lubrication Equipment Questionnaire. [CLICK HERE FOR FORM.](#)

MISCELLANEOUS EQUIPMENT

Code: 12028326



Suction Gun
16 ounce capacity
12" Flex Hose

Code: 10185364



2" FPT Full Port Ball Valve
Nozzle, Polypropylene

Code: 10182112



2" Male Pipe Thread Lockable Fill
Cap, Pressure Cap Valve opens at 2
½ lbs to reduce pressure while the
vacuum release opens at 1 ½ oz.
when tank cools.

Code: 12032195



2" FPT Mushroom Vent with
Screen

Code: 10183996



50 Gallon Tank with Prevent
Fill Cap.
23 ¼" Wide x 24" Tall x
23 ¼" Deep

Code: 10183752



100 Gallon Tank with Prevent
Fill Cap.
45 ¼" Wide x 24" Tall x
23 ¼" Deep

Code: 12038343



21 Gallon Capacity Oil Drain
•Level Gauge
•4.2 Gal Collection Bowl
•Anti-splash Screen/Filter
•Removable Tool Tray
•Pressurize with air to remove
oil

Code: 12023454



21 Gallon Waste Oil Suction
•Level Gauge
•Removable Tool Tray
•4 Piece Probe Set
•Pressurize with Air to suck
used oil into drain

Code: 12038040



55 Gallon/ 400 LB Drum
Dolly Equipped with 2 castors
and 2 fixed wheels

Code: 12029419



55 Gallon/ 400 LB Drum
Dolly Equipped with 2 castors
and 2 fixed wheels and Reel
Mounting Plate

Code: 10184198



16 Gallon Oil Hand Pump
Shown with Optional 16 Gal.
Dolly Code **10064452**

Code: 12035976



110 Volt AC Liquid Pump
•Pumps Fuel Treatment,
Diesel, Bio Diesel Kerosene
•¾ x 20' Hose
•Manual Nozzle
•Electronic In-Line Meter
•20 GPM



DRUM HANDLING

WESCO
Industrial Products, Inc.



55 gal. Truck

Wheel Type	Code
Moldon	10185231
Polyolefin	10185286

- Cast iron center
- Four wheel design
- Replaceable hard faced double beveled nose prongs

SAMSON



16 gal. (120#) Roll-A-Round Base

Code: 12038349

- Four ball bearing swivel casters
- Screw clamps
- Use with 120 lb. containers



55 gal. Open Drum Truck

Code: 10185273

- Transports drums in a vertical position
- 1000 lb. capacity
- Weight 70 lbs.
- Heavy duty 5" x 2" polyolefin caster with roller bearings

SAMSON



5 Gal. (35#) Pail Band Dolly

Code: 10183855

- For use with any 5 gal./35 lb. container

16 gal. (120#) Drum Band Dolly

Code: 10064452

- For use with any 16 gal./120 lb. container

WESCO
Industrial Products, Inc.

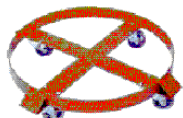

Drum Dolly

Size	Code
30 Gallon	10062837
55 Gallon	10182995

- 1000 lb. capacity
- Weight 22 lbs.
- All welded steel frame construction with reinforced outriggers

WESCO
Industrial Products, Inc.

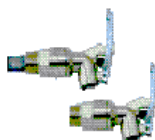

Drum Faucets

Code: 10182937

- Zinc die cast alloy
- Fits 3/4" bung hole.
- Teflon® gasket
- Can be padlocked in closed position
- FM approved for viscous liquids only



Drum Wrench-Poly Drum

Code: 10010057

- Wrench will not corrode or be affected by acid.
- Light weight



Drum Wrench-Metal Drum

Code: 10010020

- Aluminum alloy
- Built-in 1.25" wrench for tightening faucets into drums



55 gal. Drum Rocker II

Code: 10021306

- Inboard polyolefin wheels
- 600 lb. capacity
- Weight 29 lbs.
- Tipping lever
- 32.5" long by 19.5" wide
- Drum distance from floor is 15"

WESCO
Industrial Products, Inc.



55 gal. Drum Lifter

Code: 10185285

- 1000 lb. capacity
- Weight 45 lbs.
- Picks up and sets down drums automatically
- Simple to set latch controls
- Use with Both Poly and Metal Drums

WESCO
Industrial Products, Inc.



2" Drum Vent

Code: 10185274

- Automatically relieves pressure at 5 PSI
- Maximum flow of 220 CFM at 20 PSI
- Fits 2" bung hole
- For drums in horizontal pouring position

WESCO
Industrial Products, Inc.



2" Brass Gate Valve

Code: 10185260

- Fast, self-closing Teflon® blade
- Fits 2" bung hole
- FM approved for use with viscous non-corrosive fluids heavier than SAE 30 or ISO 68.

DRUM AND TOTE HEATERS



55 Gallon Drum Heater Band

Code: 10181534

16 Gallon Drum Heater Band

Code: 10182559

Drum and tote heaters allow product to pump in extremely cold conditions.

3" heating band width.

- Standard voltage is 120 VAC, Not available in 12VDC
- Shipped with 6' power cord.
- Indoor use only.
- Thermostat included for precise heat control. Temperature range from 50°-425°F.

IBC Oil, Water, DEF Tote Heater Blanket

Code: 12027361



Fits several tote tank sizes with adjustable nylon straps and buckles.

Includes standard plug for an easy electrical connection.



Controls temperature easily with adjustable thermostats.



Protects contents and tote tank surface from heat damage with manual reset high-limit safety thermostats.

- Full Coverage Plug and Play System
- 2 zone heating.
- Standard voltage is 120 VAC
- 1440 Watts
- Thermostat included for precise control from 50°-160°F.
- 6 Ft Standard 3 Prong Power Cord
- 42" Height, 160" Minimum Perimeter, 192" Maximum Perimeter
- Optional Insulated Top Cover is Available

Additional heaters are available by special order. These heaters include:

- Grease Tote Heater Blankets
- Gas Cylinder Heaters
- Explosion -Proof Heaters
- Bottom Heaters

Please call for more information.

DESICCANT BREATHERS



Air Sentry Desiccant Air Breathers

- 10184020 D101 5" x 5" Slip Fit Breather
- 10184010 D102 8" x 5" Slip Fit Breather
- 10175589 D103 8" x 5" 1" Male Pipe Thread Breather
- 10175704 D108 10" x 5" 2" Male Pipe Thread Breather
- 10179368 Z132 3" x 2" Mini 1/2" Female Pipe Thread Breather
- 12037782 Z134 3.25" x 5" Mini 1/2" FPT Breather

X-Series Breathers incorporate 2- Check Valves to control flow in and out of breather to extend breather life and has Re-usable Top Cap re-used with Refill Bead Cartridges

- 12019184 X101 5" x 5" Slip Fit Breather
- 12033163 X102 8" x 5" Slip Fit Breather
- 12038502 Replacement Cartridge for X-102

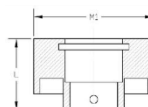

- 10181427 Bayonet Adapter 1" Slip Fit
- 10175601 Bayonet Adapter 1" FPT



SPRAYERS AND APPLICATORS



Code 10029952

Sprayer for Viscous Liquids

- 1.3 gallon capacity
- Designed for spraying “heavier liquids” such as chain and cable lubes
- Solvent resistant
- High impact plastic
- 7” brass wand
- Brass valve
- Chemical resistant seals and gaskets



Code 10010035

Sure Shot Sprayer Green-32 oz.

- Provides an alternative to aerosols when using bulk products as replacements.
- Can accept compressed air through injection valve
- Includes 1 Multipurpose Nozzle. Nozzle is set for regular mist; for pin stream, remove #303 Spiral.
- Withstands pressure up to 200 PSI
- Durable metal can
- Holds 32 oz.
- Reusable



Code 12032141

Non-Toxic Pressure Sprayer

- Wheel Mounted 6 Gallon Tank
- Spray low viscosity detergent liquids such as lubrication oils and soaps
- Fill Tank to $\frac{3}{4}$ it’s capacity with fluid, pressurize tank with 90-120 PSI.
- Unit works independently without requiring continuous connection to compressed air line.

ANTI-SEIZE BRUSH APPLICATOR



Brushmaster

Code 10172340

- Designed to screw on to pint containers.
- Less messy.
- Allows user to place the product where desired.
- Gets the product into threads.
- Prevents product loss if container is tipped over.
- Provides even flow of product.

OIL SAFE CONTAINERS

Oil Safe[®]

For use with lubrication oils only. Do not use with solvents or fuels.



Code: 10185102 Code: 10070859 Code: 10066566 Code: 10070860
2 Liter 3 Liter 5 Liter 10 Liter

Drums

Fully interchangeable with Oil Safe Lids, these drums have an extra wide neck opening for rapid pouring and easy cleaning. With anti-static agents and UV protection built in, the drums are extremely durable. Semi-transparent design with graduations in US and metric allow you to quickly see the amount of lubricant in the drum. Available in 2, 3, 5 and 10 liter (quart) sizes.

Stumpy Spout Lid

This wide spout model is especially designed for applications where a higher lubricant flow is required. Spout Opening ID=1", OD=1.125"

Color	Code
Yellow	10066617
Red	10070861
Blue	10184575
Black	10182860
Light Green	10184120
Dark Green	10070596
Orange	10184457
Purple	10185255
Gray	10183035



Available Accessories

Stumpy Spout Hose Extension

Code: 10070863



Stretch Spout Lid

Designed for use where precise pouring of lubricants is required, including hard to reach areas. Ideal for lower viscosity lubricants. Spout Opening ID=.50", OD=.625"

Color	Code
Yellow	10066567
Red	10070862
Blue	10183840
Black	10184775
Light Green	10184602
Dark Green	10183049
Orange	10181510
Purple	10184176
Gray	10182851



Available Accessories

Stretch Spout Hose Extension

Code: 10070864



Utility Lid



Multi-purpose lid with large outlet hole ensures controlled, fast pouring of lubricants. Match this lid to a 3, 5 or 10 liter drum for use with the Oil Safe Pump.

Color	Code
Yellow	10184446
Red	10070865
Blue	10183913
Black	10183036
Light Green	10184287
Dark Green	10185293
Orange	10182989
Purple	10071127

Mini-Spout Lid



This lid has a very small pour spout, allowing for controlled pouring into small reservoirs or fill ports. Spout Opening ID=.25", OD=.375"

Color	Code
Yellow	10070102
Red	10070101
Blue	10070103
Black	10184129
Light Green	10182327
Dark Green	10185282
Orange	10182346
Purple	10185271
Gray	10182327



Code: 10070866

Hand Pump

This high volume, down-stroke discharge pump delivers 1 quart for approximately 14 strokes. Match with an Oil Safe Utility Lid and 3, 5 or 10 liter drum. Includes 4 foot hose and anti-drip nozzle.

Available Accessories

Code: 10185242

Reduces the fitting on the pump hose to 1/4" ID allowing you to fill very small openings.



Storage Lid



With this lid, Oil Safe Drums can be pre-filled for storage or easy transport. This is a convenient alternative to handling bulky 5 gallon buckets.

Color	Code
Yellow	10182999
Red	10183975
Blue	10184291
Black	10183066
Light Green	10185283
Dark Green	10184052
Orange	10185272
Purple	10185256

TRILOGY OIL FILTER SYSTEMS

Typical Delivery Time for the Filter Systems is 7 to 14 Business Days

TRILOGY 5 FILTER SYSTEM

Medium Off-Line, Max 10 Gal. Oil Capacity Engines
10206467

TRILOGY 15 FILTER SYSTEM

Large Off-Line, Max 20 Gal. Oil Capacity Engines
10028983



TRILOGY 3 FILTER ELEMENT

Replacement Filter Element for the Small Trilogy 3
10205731 Case of 6

TRILOGY 5 FILTER ELEMENT

Replacement Filter Element for the Medium Trilogy 5
10064274

TRILOGY 15 FILTER ELEMENT

Replacement Filter Element for the Large Trilogy 15
10029209



TRILOGY DRAIN KIT

Convenient Drain Kit for Trilogy 3, Trilogy 5, Trilogy 15
10181725



TRILOGY OIL ANALYSIS PROBE

Disposable Quick Connect Oil Analysis Probe
10181234

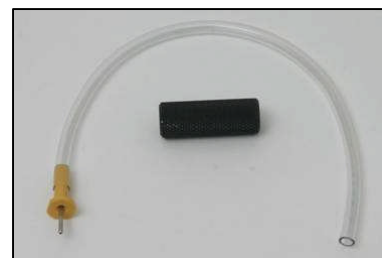

PORTABLE OIL FILTRATION SYSTEMS



Designed to clean and filter oils at the machine.

Code 9480

Includes:

- 1 HP 110V motor
- 12 GPM gear pump
- Water removal filter
- Dirt removal to meet ISO count of 16/14/12.
- Oil sample valves before and after filters.
- Will help maintain oil by removing small particles.
- Can be moved from machine to machine or tank to tank.

Typical fluids cleaned: Hydraulic Oil, Turbine Oil, Gear Oil



Portable Design to clean and filter oils at the machine.

Code 12026436

- ¾ HP 120 Volt Single Phase, 8 GPM Pump
- Starter Switch, Pressure Switch, Pressure Gauge
- 2 Filter Housings Removes Contaminants as low as 1 Micron
- Removes Water from Petroleum based Fluids
- Includes 10' Suction and 10' Discharge Hoses
- Sample Valve Built in
- 12' 14/3 Wire Power Cord
- Mounted on Welded Portable Frame
- Replacement Element: Code 12026437



STATIONARY OIL FILTRATION SYSTEM

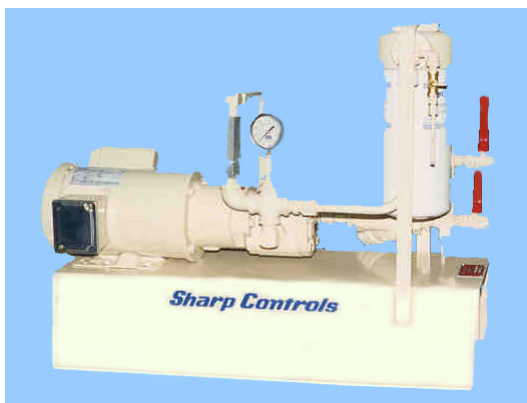

Custom manufactured to specification. Designed for stationary installation. Will clean large systems of particles, water, and contaminants.

Includes:

- Sampling ports before and after the filter.
- Uses a gear pump for no-prime starting.
- 65 psi relief valve.
- Motors available from ½ HP to 5 HP.
- Pumping rates from 5 GPM to 50 GPM.
- Indicator alerts when filter is full.
- Cleanable strainer for large contaminants.

Typical fluids cleaned: Hydraulic Oil, Turbine Oil

OIL ANALYSIS Test Kits

ALS Staveley Standard Oil Analysis



Includes:

- Wear Metal/Additive Depletion
- Contaminants
- Oil Condition
- Viscosity
- TAN/TBN

1 Kit (2 Oil Samplers): \$40.00
Code 12043495 -- 00020R00 -- 0010E00

1 Case (10 Oil Samplers): \$200.00
Code 12043496 -- 000100R00 -- 00050E00

ALS Staveley Advanced Particle & Oil Analysis



Includes:

- Small & Large Particle Detection
- Wear Metal/Additive Depletion
- Contaminants
- Oil Condition & Viscosity
- TAN/TBN

1 Kit (1 Oil Sampler): \$37.20
Code 12043497 -- 0018R60 -- 0009E30

1 case (10 Oil Samplers): \$372.00
Code 12043498 -- 00186R00 -- 00093E00

Holt CAT Single Sample Kit



Includes:

- Wear Metal/Additive Depletion
- Contaminants
- Oil Condition
- Viscosity (Engine Oil Only)
- Large Particle Detection

1 Kit (1 Oil Sampler): \$32.50
Code 12051062 -- 00016R25 -- 0008E13

Oil Extraction Vacuum Pump & Tubing



Includes:

- Vacuum Pump for Oil Sampling
- Pump also includes Sampling Valve
- 100' Disposable Tubing

Fluid Sampling Pump: \$75.00
Code 12051665 -- 00035R70 -- 0018E75

100ft. Fluid Sampling Tubing: \$17.50
Code 12051666 -- 0008R75 -- 004E38

Oil Extraction Retro Valve/Needle Valve/Tubing

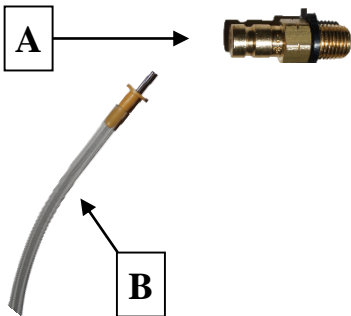

(A) NEW Retro Oil Sampling Valve w/Dust Cover –
\$53.00 Code 12039509 – 0026R50 – 0013E20

(B) Disposable Oil Analysis Probe with Quick Connect (10 Per Package) -
\$130.00 Code 12047925 – 00065R00 – 0032E50

STANDARD TOTE TANKS

Standard Poly Grease Tote

- 2700 Pound Capacity, 330 Pounds Empty
- Heavy-duty Polyethylene Construction
- Chemical & Corrosion Resistant
- Flexible Follower Plate
- Two 2" Fittings with Plug, 3" Ball Valve Adapter
- 45.5" Diameter (base is 49"), 76.75" High
- Pressure & Vacuum Vents
- Accepts All Standard Forklifts



Standard "Passport" Oil Tote

- 330 Gallon Capacity, 174 Pounds Empty
- Heavy-duty Polyethylene Construction
- Chemical & Corrosion Resistant
- 5 5/8" Lockable Screw Cap,
- 2" Threaded Fitting, 2" Banjo Ball Valve
- Stackable 40" Wide, 48" Deep & 54" High
- 4-way Access Base Accepts Standard Forklifts
- Protective Steel Cage

SPECIAL ORDER TOTE TANKS

Special Order “Yellow Bottom” Oil Tote

- 330 Gallon Capacity, 288 Pounds Empty
- Heavy-duty Polyethylene Construction
- Chemical & Corrosion Resistant
- Sloped Bottom Allowing for Complete Drainage
- 7” Lockable Screw Cap, 2” Threaded Fitting, 2” Banjo Ball Valve
- Stackable 45” Wide & Deep, 62” High
- Pressure & Vacuum Vents
- 4-way Easy Access Base Accepts All Standard Forklifts

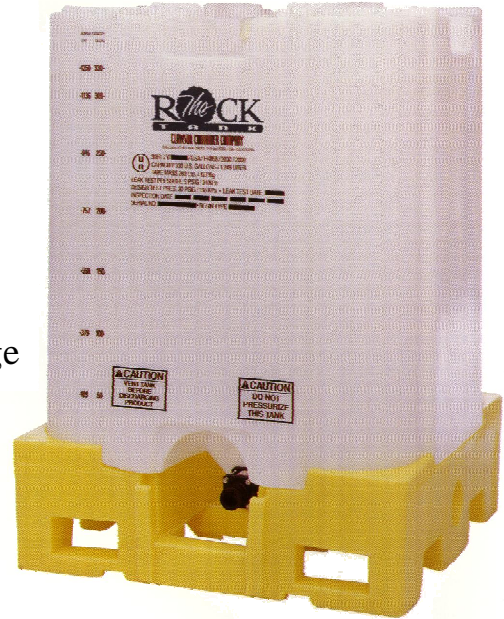

Special Order Stainless Steel Oil Tote



- 350 Gallon Capacity, 500 Pounds Empty
- Stainless Steel Construction
- Chemical & Corrosion Resistant
- 22.3” Opening With 2” Flush Fitting Lid, 2” Reversible Stem Valve, Pressure & Vacuum Vents
- No Heel Bottom
- Independent Leg Pad Weld Accepts All Standard Forklifts
- Stackable 42” Wide, 48” Deep, 49.75” High

Special Order Steel Grease Totes Also Available